

# ROYAL

Store Fixture



*Refrigerated rear storage.*



## *P*REVIEW DELI

The cost saving alternative to  
expensive display cases

MODEL PD-03-L-SC  
PD-05-L-SC  
PD-06-L-SC  
PD-08-L-SC

**Deli / Dairy / Prepared Foods / Bakery  
Double Duty**

A DIVISION OF  
**PARISI**  
INCORPORATED

## Deli, Salad, Prepared Food Non-Refrigerated Mezzanine Shelf Fixed Display Ledge on Top of Case

### TYPICAL SECTION

Not to scale.

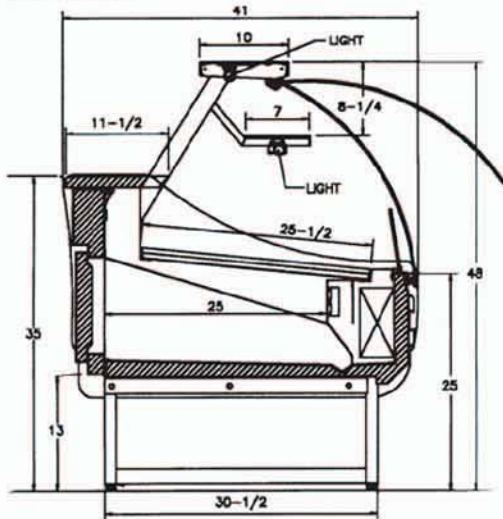

### FEATURES

**Exterior Finish.** Metal construction with rugged steel base, adjustable legs and high impact vinyl cart bumper.

**Interior Finish.** Stainless steel.

**Lighting.** Two levels of energy efficient illumination with remote ballast.

**Self Contained.** Unit complete with condensate evaporator.

**Low Velocity Fan Operated.**

**Aluminum Finned Copper Tube Coils**

**Standard Digital Control.**

**Tempered Lift Front Glass with Hydraulic Hinges.**

**Refrigeration Without Rear Doors.**

**Refrigerated Rear Storage Below with Hinged Doors.**

**Non-Refrigerated Glass Mezzanine Shelf.**

**Fixed Display Ledge on Top of Case.**

**CFC-Free Insulated, Foamed in Place Interior Tank.**

**Rear Work Surface. Stainless Steel.**

**Scale Outlet in Rear.**

**Double Pane Glass Ends for Display Area.**

**Insulated End Panels.**

**UL Listed & UL Sanitation Classified to NSF-7.**

**Warranty: One Year Parts & Labor**

### SPECIFICATIONS

Note: 8' Self-contained units require two dedicated outlets, (1) 115V & (1) 239V.

LIFT FRONT SELF-CONTAINED					
MODEL	LENGTH	CONDENSING Unit H.P.	CASE ELECTRICAL		WEIGHT LBS
			AMPS @115V	AMPS @230V	
PD03LSC	39-1/2"	1/3	17.0	N/R	353
PD05LSC	59"	1/2	18.2	N/R	428
PD06LSC	75"	1/2	20.5	N/R	540
PD08LSC	98-1/2"	(2) 1/3	15.0	8.8	624

LIFT FRONT REMOTE*					
MODEL	LENGTH	**BTU'S/HR/FT	AMPS	AMPS	WEIGHT LBS
			@115V	@230V	
PD03LRM	39-1/2"	3425	3.0	N/R	303
PD05LRM	59"	4764	3.6	N/R	371
PD06LRM	75"	5785	5.3	N/R	438
PD08LRM	98-1/2"	6850	6.3	N/R	522

\*Floor drain required  
If no floor drain provided, evaporative drain pan must be ordered  
\*\*BTU/HR are at +20°F (evaporator) and 90°F ambient  
Cases engineered to operate at 75° F and 55% RH



### PLAN VIEW

Specifications subject to change without notice.

Not to scale.

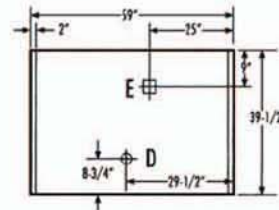

E – Electrical Connection  
D – Drain Connection  
(Remote Units Only)

### OPTIONS

**Optional 5 Year Warranty for Compressor.**

**Scale Ledges Available.**

**Stainless Steel Step Shams Available.**

**Condensate Pan Kit.** For remote applications when floor drains are not available.

**Special Order Colors Available.**

**Represented By:**

